

U. Oppermann.

Combined Lathe and Gear-Cutter.

118262

PATENTED AUG 22 1871

Fig. 1.

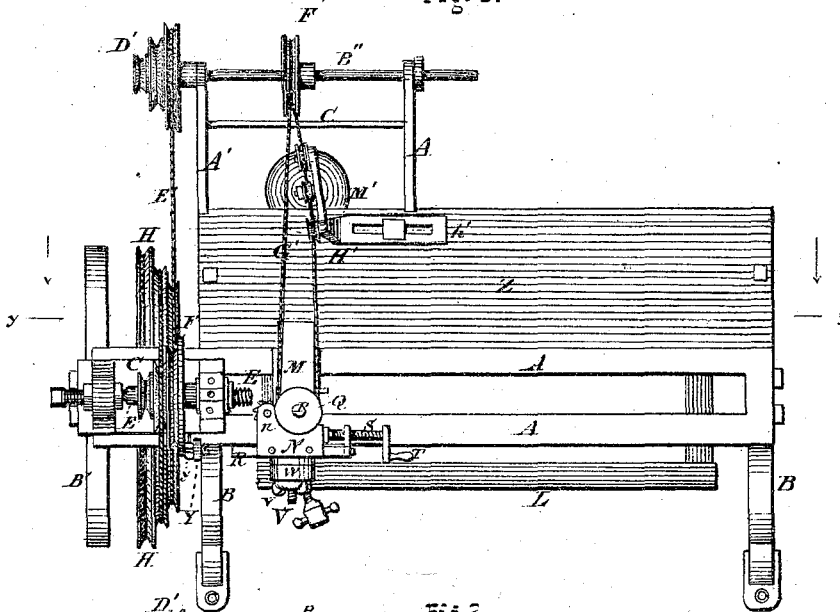
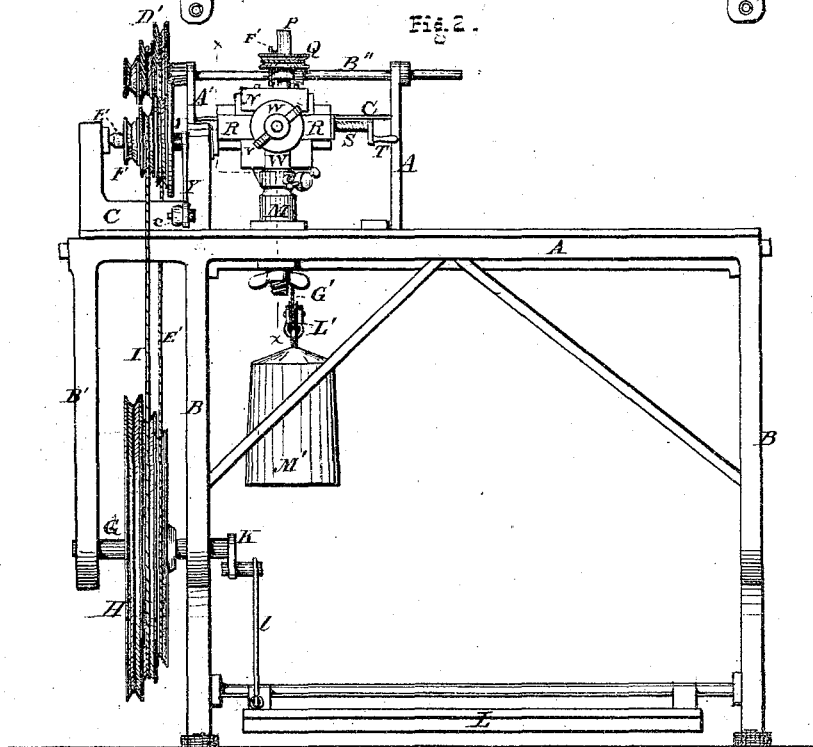

Fig. 2.



Witnesses.

Ch. Poole
John R. Young

Inventor.

U. Oppermann, by
Orinelle W. Byer, his
 Attys.

U. Oppermann.

Combined Lathe and Gear-Cutter. 118262

Fig. 3.

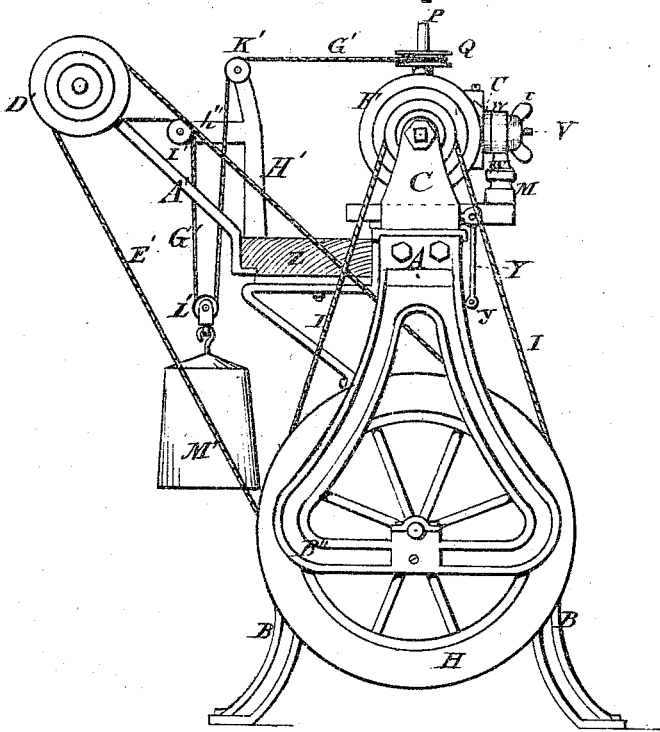
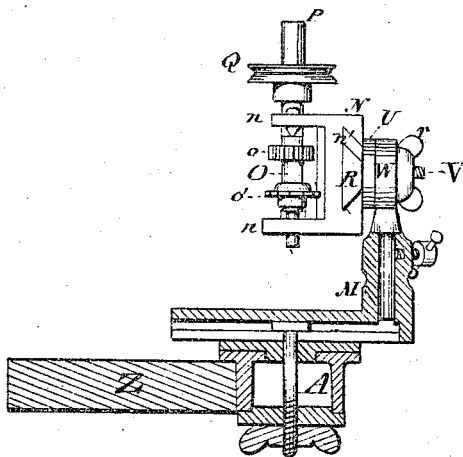

Fig. 4.



Witnesses.

Ch. Poole
John B. Young

Inventor.

U. Oppermann, by
Prindle and Oyer, his
Attys.

U. Oppermann.

Combined Lathe and Gear Cutter.

118262

Fig. 5.

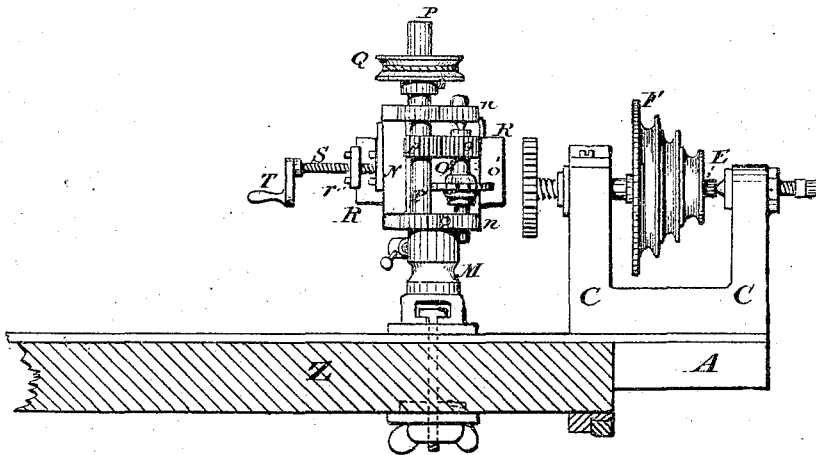

Fig. 6.

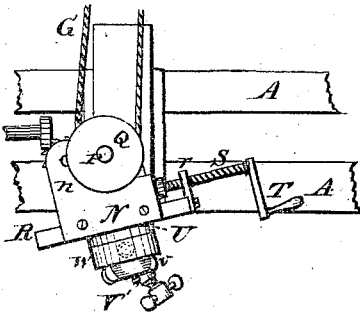

Fig. 7.

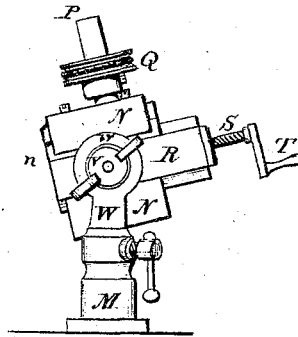
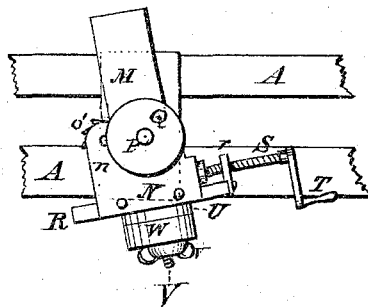

Fig. 8.



Witnesses.

C. H. Poole
John B. Young

Inventor.

U. Oppermann, by
Orinoble & Oyer, his
 Attys.

UNITED STATES PATENT OFFICE.

ULRICH OPPERMANN, OF WASHINGTON, DISTRICT OF COLUMBIA.

IMPROVEMENT IN COMBINED LATHE AND GEAR-CUTTERS.

Specification forming part of Letters Patent No. 118,262, dated August 22, 1871.

To all whom it may concern:

Be it known that I, ULRICH OPPERMANN, of Washington city, in the county of Washington and in the District of Columbia, have invented certain new and useful Improvements in Combined Lathe and Gear-Cutters; and do hereby declare that the following is a full, clear, and exact description thereof, reference being had to the accompanying drawing making a part of this specification, in which—

Figure 1 is a plan view of the upper side of my device. Fig. 2 is a front elevation of the same. Fig. 3 is an elevation of the head-block end of the device. Fig. 4 is a vertical cross-section on the line *xx* of Fig. 2. Fig. 5 is a rear elevation of the head-block and gear-cutting devices, with the table removed, on the line *yy* of Fig. 1. Fig. 6 is a plan view of the upper side of the cutting devices as arranged for cutting the teeth of a miter-gear. Fig. 7 is a front elevation of the same; and Fig. 8 is a plan view of said parts, showing the same adjustment by means of a change in the position of the lathe-rest block.

Letters of like name and kind refer to like parts in each of the figures.

The object of my invention is the production of a gear-cutter that is capable of being attached to and combined with an ordinary lathe so as to enable said devices to be furnished at a much less cost than would be possible were each complete in itself, and also to cause them to occupy less room; and it consists, principally, in the peculiar construction of the means employed for communicating the motion of the driving-pulleys of the lathe to the cutter-spindle, substantially as is hereinafter shown. It consists, further, in the peculiar construction of the cutter-head and its combination with the tool-post of the lathe, substantially as is hereinafter set forth.

In the annexed drawing, A represents the bed-plate, supported upon suitable standards B, and provided with a head-block, C, which contains a spindle, E, having secured thereon a cone of pulleys, F, all of usual construction. Secured to and extending downward from the head-block end of the bed-plate is a hanger, B', upon which and the adjacent standard B is journaled a shaft, G, secured to and revolving with which is a cone of pulleys, H, that corresponds in relative size and in vertical position with the cone F, and is

connected with the same by means of a belt or cord, I. Upon the inner end of the shaft G that projects beyond the standard B is provided a crank, K, which is connected with a pivoted treadle, L, by means of a rod, *l*, so that, by giving to said treadle a reciprocating movement, said crank is caused to revolve, and, through the cones F and H and belt I, impart to the spindle E a rotary motion. A hollow tool-post, M, for receiving an ordinary hand-tool or slide-rest, clamped upon the bed-plate, completes the lathe portion of the device, the various parts of which are constructed and combined in the usual manner. The cutter-head N consists of a rectangular plate of metal, from opposite sides of which extend forward, in parallel lines and at a right angle to the face thereof, two lugs, *n*, within which are pivoted the cutter-spindle O and driving-spindle P, each of which is provided with suitable pinions, *o* and *p*, respectively, that mesh together and cause said spindles to move simultaneously in opposite directions whenever either is turned. A pulley, Q, secured to or upon the upper end of the spindle P, above the cutter-head N, furnishes a means whereby the same may be connected with the driving mechanism, while the usual arrangements are made for removing from and adjusting to place the cutter-spindle O and for securing thereon the cutters *o'*. The cutter-head N is provided at its rear side with a dove-tail groove that extends from end to end in a line at a right angle to the line of the cutter-spindle, and receives a corresponding slide or way, R, upon which way said head may be moved longitudinally. A gib, *n'*, and the usual set-screws furnish a means whereby said head may be caused to fit to or upon said slide as closely as may be desired. Swiveled within the cutter-head N, in front of the slide R, is one end of a screw, S, that from thence extends outward in a line with said slide and passes through a threaded lug, *r*, secured to and projecting forward from the end of the latter. A crank-handle, T, attached to the outer end of said screw, permits the same to be revolved, by which means the cutter-head may be moved back and forth upon the slide. Secured upon the rear face of the slide R, at its center, is a circular collar, U, from which projects horizontally outward a stud, V, which stud passes through a circular head, *w*, that corresponds in size and shape to said collar U and

forms part of a bar, W, the lower end of which fits into the tool-post M. A thumb-nut, *v*, fitted to or upon the threaded end of the stud V binds said parts firmly together, when desired. As thus constructed and arranged, it will be seen that, as the slide R is swiveled within the bar W and said bar within the tool-post, said cutter-head can be so adjusted as to have any desired line of motion with relation to the lathe-spindle, while the vertical position of said head is secured in the same manner as is that of an ordinary hand-tool rest. The blank to be cut is attached to and, if desired, turned up upon the outer end of the lathe-spindle; and, in order that when thus attached said blank may be secured in position while the cutter is in operation and then rotated to the exact distance required for another tooth, the forward end of the cone F is used for a dial-plate and provided with the usual series of pin-holes, which receive a corresponding pin, *y*, that is attached to and extends horizontally rearward from one end of a spring, Y, the opposite end of which is pivoted upon a lug, *c*, that projects outward from the lower part of the head-block C. When in use the spring Y is turned upward to position and the pivot-screw at its lower end turned so as to hold said spring firmly in place, radially and longitudinally, without interfering with its free movement toward or from the dial-plate. When not in use the pivot-screw of the spring is loosened and the latter turned downward, as shown in Fig. 3. Secured to and extending horizontally outward from the rear side of the lathe-bed, immediately below its upper face, is a table, Z, of usual construction, secured to and extending upward and rearward from which are two standards, A', that furnish a support for, and have pivoted within their upper ends, a short shaft, B''. A brace, C, extending horizontally between said standards, secures the relative lateral positions of the same. Attached to the outer end of the shaft B'' is a cone, D', composed of a series of pulleys, which pulleys correspond in relative size and are placed in a line with the driving-pulleys H, so as to receive a belt or cord, E', from the same. A grooved pulley, F', is secured to and made adjustable longitudinally upon said shaft between the standards, and receives a band or cord, G', which passes around and imparts motion to the pulley Q when said shaft revolves; but, as the relative positions of said pulleys Q and F' are continually changing when the machine is in operation, the following-described means are employed to insure the necessary tension of said cord G. A standard, H, provided with a slotted foot, *h'*, is secured to or upon the table Z, and, from thence extending vertically upward, has its upper end about in a line horizon-

tally with the pulley Q. An arm, *h''*, extending rearward from said standard in a line with the lower side of the pulley F', and slightly toward the head of the lathe, has pivoted upon its side and at its end a grooved pulley, I', while a similar pulley, K', is pivoted upon the corresponding side of the standard at its upper end. The cord G' now passes from the upper side of the pulley F' to and around the pulley Q, from thence rearward over the small pulley K', from thence downward through a single shive, L', to which is attached a weight, M', and from thence upward around the small pulley I' to the lower side of the pulley F', by which arrangement a uniform and adjustable pressure is at all times maintained upon said cord, while variations in the distance between the pulleys Q and F' are compensated for by the rise or fall of the weighted shive. When the cutter-head is used near to or further from the head-block the position of the standard H' may be correspondingly changed so as to bring its pulleys in a line substantially with the driving and cutter-head pulleys.

The especial advantages obtained by this construction and combination of parts are: First, it enables the production of a blank and the completion of a gear without the removal of the former from the spindle upon which it was turned, by which means greater accuracy is obtained than would be possible were the different operations performed in separate machines. Second, by combining two heretofore separate machines in one a material reduction in cost is secured, and a corresponding reduction obtained in the space necessary for their proper use.

Having thus set forth the nature and merits of my invention, what I claim as new is—

1. In combination with the pulleys H and Q and suitable cords or belts, the standards A', connected together by means of the brace C', the shaft B'', the standard H', the pulleys D', F', I', and K', the shive L', and the weight M', substantially as and for the purpose shown.

2. The cutter-head N provided with the lugs *n*, the spindles O and P provided with the pinions *o* and *p*, the pulley Q, the way R provided with the lug *r* and collar U, the screw S, the handle T, the stud V, the nut *v*, and the bar W provided with the head *w*, when constructed substantially as described, and combined with the tool-post M, in the manner and for the purpose substantially as set forth.

In testimony that I claim the foregoing I have hereunto set my hand this 28th day of June, 1871.

ULRICH OPPERMAN.

Witnesses:

GEO. S. PRINDLE,
EDM. F. BROWN.